

# Technical Product Sheet

## BV4-6666R-PN10/PN16/PN40 - Aluminium Gearbox

Ball valve, full bore, split body, flanged PN10/PN16/PN40, with Rotork gearbox

Face to Face Standard: EN 558-1 series 27



Item Number	Belven Ref.
043D77F5015	BV4-6666R-PN40-DN015 - GEARBOX
043D77F5020	BV4-6666R-PN40-DN020 - GEARBOX
043D77F5025	BV4-6666R-PN40-DN025 - GEARBOX
043D77F5032	BV4-6666R-PN40-DN032 - GEARBOX
043D77F5040	BV4-6666R-PN40-DN040 - GEARBOX
043D77F5050	BV4-6666R-PN40-DN050 - GEARBOX

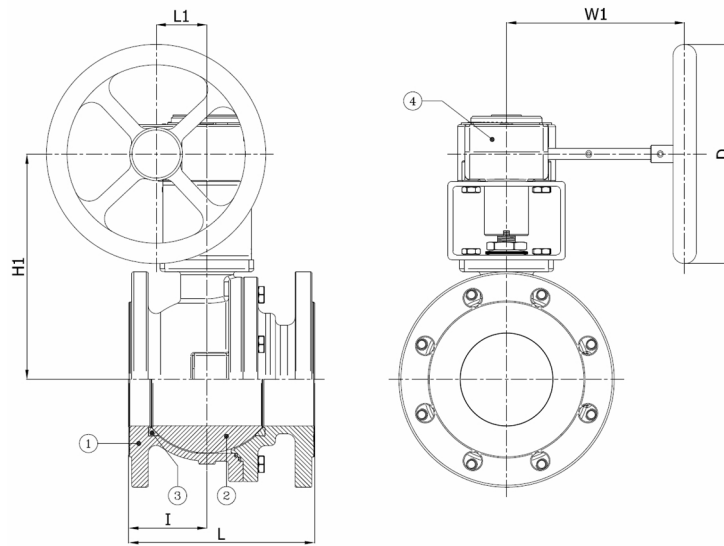

DN/Size	L	H1	I	L1	W1	D	Press.Cl.	Weight(kg)
DN15 (1/2")	115	110	49	45	119	100	PN40	4.70
DN20 (3/4")	120	115	51	45	119	100	PN40	5.40
DN25 (1")	125	132	54	45	119	100	PN40	6.80
DN32 (1 1/4")	130	136	55	45	119	100	PN40	8.20
DN40 (1 1/2")	140	164	51,5	46	166	125	PN40	10.20
DN50 (2")	150	169	57,5	46	166	125	PN40	13.90

Item 1	Item 2	Item 3	Item 4
Body Material	Ball Material	Seat Material	Actuator Material
Stainless steel : 1.4408 (CF8M)	Stainless steel : A182-F316 / A351-CF8M	RPTFE	Aluminium

Belven N.V.

Blokhuisstraat 24 | 2800 Mechelen | Belgium

Tel. 015 29 40 70 | Fax. 015 20 14 13 | [info@belven.com](mailto:info@belven.com) | [www.belven.com](http://www.belven.com)

We keep the right to change the mentioned dimensions, weights, values and materials at any time without prior or direct notice.