

## BV40-2413E-PN10

Clapet de retenue à double battant, montage "sandwich" entre brides PN10

Norme d'écartement: EN 558-1 série 16



N° d'article	Réf. Belven
402042E0300	BV40-2413E-PN10-DN300
402042E0350	BV40-2413E-PN10-DN350
402042E0400	BV40-2413E-PN10-DN400
402042E0450	BV40-2413E-PN10-DN450
402042E0500	BV40-2413E-PN10-DN500
402042E0600	BV40-2413E-PN10-DN600

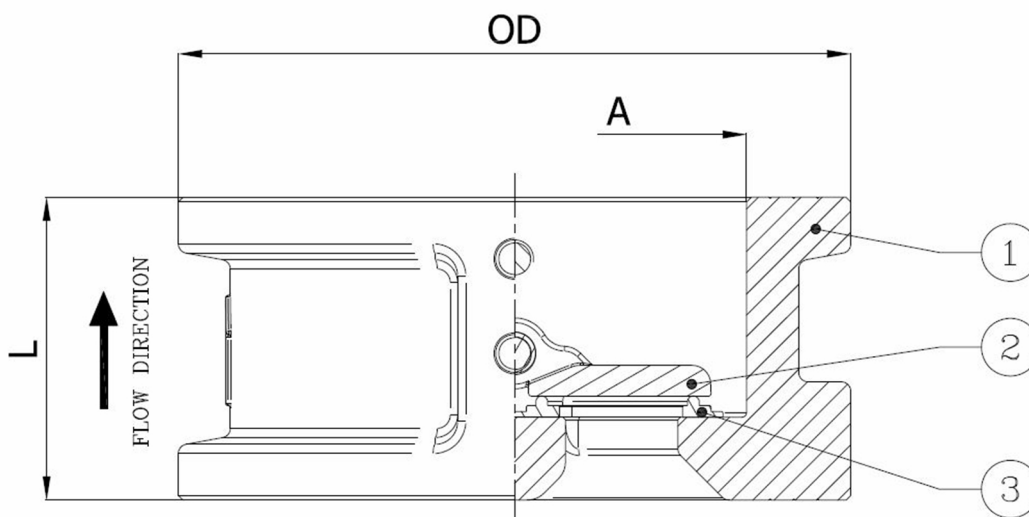

DN/Pouce	L	OD	A	Cl. press.	Poids(kg)
DN300 (12")	114	378	325,5	PN10	33,50
DN350 (14")	127	438	360	PN10	55,00
DN400 (16")	140	489	410	PN10	75,00
DN450 (18")	152	539	467	PN10	101,00
DN500 (20")	152	594	515	PN10	111,00
DN600 (24")	178	695	624	PN10	172,00

Item 1	Item 2	Item 3
<b>Matériau Corps</b>	<b>Matériau Clapet</b>	<b>Matériau Siège</b>
Fonte ductile: GGG40 + revêtement epoxy	Alubronze C954	EPDM