

Technical Product Sheet

BV4-4466T-PN16 - Aluminium Gearbox

Ball valve, full bore, split body, flanged PN16, with Rotork gearbox

Face to Face Standard: EN 558-1 series 27



Item Number	Belven Ref.
043D57F5065	BV4-4466T-PN16-DN065 - GEARBOX
043D57F5080	BV4-4466T-PN16-DN080 - GEARBOX
043D57F5100	BV4-4466T-PN16-DN100 - GEARBOX
043D57F5125	BV4-4466T-PN16-DN125 - GEARBOX
043D57F5150	BV4-4466T-PN16-DN150 - GEARBOX
043D57F5200	BV4-4466T-PN16-DN200 - GEARBOX

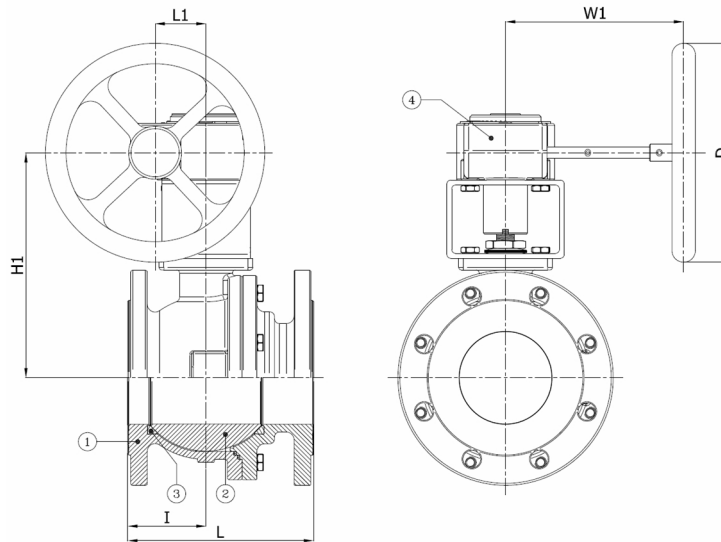

DN/Size	L	H1	I	L1	W1	D	Press.Cl.	Weight(kg)
DN065 (2 1/2")	170	181	61	46	166	125	PN16	19.90
DN080 (3")	180	217	75,5	52	194	224	PN16	23.80
DN100 (4")	190	230	80	52	194	224	PN16	30.30
DN125 (5")	325	252	149	52	194	224	PN16	53.30
DN150 (6")	350	315	157	65	236	256	PN16	81.90
DN200 (8")	400	360	190	80	376	400	PN16	122.00

Item 1	Item 2	Item 3	Item 4
Body Material	Ball Material	Seat Material	Actuator Material
Carbon steel : 1.0619 (WCB)	Stainless steel : A182-F304 / A351-CF8	PTFE	Aluminium

Belven N.V.

Blokhuisstraat 24 | 2800 Mechelen | Belgium

Tel. 015 29 40 70 | Fax. 015 20 14 13 | info@belven.com | www.belven.com

We keep the right to change the mentioned dimensions, weights, values and materials at any time without prior or direct notice.