

BV38-6666E-PN10

Clapet anti-retour à battant, montage "sandwich" entre brides PN10

Norme d'écartement: Standard d'usine



N° d'article	Réf. Belven
382077N0250	BV38-6666E-PN10-DN250
382077N0300	BV38-6666E-PN10-DN300
382077N0350	BV38-6666E-PN10-DN350
382077N0400	BV38-6666E-PN10-DN400
382077N0450	BV38-6666E-PN10-DN450
382077N0500	BV38-6666E-PN10-DN500
382077N0600	BV38-6666E-PN10-DN600

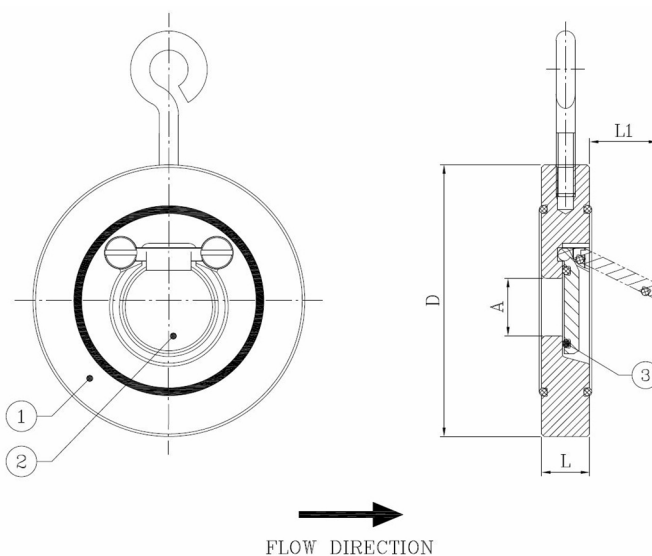

DN/Pouce	L	D	A	L1	Cl. press.	Poids(kg)
DN250 (10")	26	330	192	190	PN10	12,60
DN300 (12")	32	380	227	220	PN10	20,50
DN350 (14")	38	440	266	250	PN10	33,50
DN400 (16")	44	491	310	290	PN10	52,00
DN450 (18")	52	541	350	340	PN10	71,00
DN500 (20")	58	596	400	390	PN10	94,00
DN600 (24")	62	698	486	470	PN10	128,00

Item 1	Item 2	Item 3
Matériau Corps	Matériau Clapet	Matériau Siège
Acier inoxydable : 1.4408 (CF8M)	Acier inoxydable : 1.4408/1.4581 (CF8M/AISI 316Nb)	EPDM