

# Technical Product Sheet

## BV10S-2366V-PN10/PN16/A150 - Lever

Wafer type butterfly valve, mounting between flanges PN10/PN16/A150, with lockable lever

Face to Face Standard: EN 558-1 Table 1 series 20

Seat made of FPM (Viton), max. operating pressure 16 bar, -5°C to 200°C



Item Number	Belven Ref.
10S003037V10050	BV10S-2366V-PN16-DN050 - LEVER
10S003037V10065	BV10S-2366V-PN16-DN065 - LEVER
10S003037V10080	BV10S-2366V-PN16-DN080 - LEVER
10S003037V10100	BV10S-2366V-PN16-DN100 - LEVER
10S003037V10125	BV10S-2366V-PN16-DN125 - LEVER
10S003037V10150	BV10S-2366V-PN16-DN150 - LEVER
10S003037V10200	BV10S-2366V-PN16-DN200 - LEVER
10S003037V10250	BV10S-2366V-PN16-DN250 - LEVER
10S003037V10300	BV10S-2366V-PN16-DN300 - LEVER

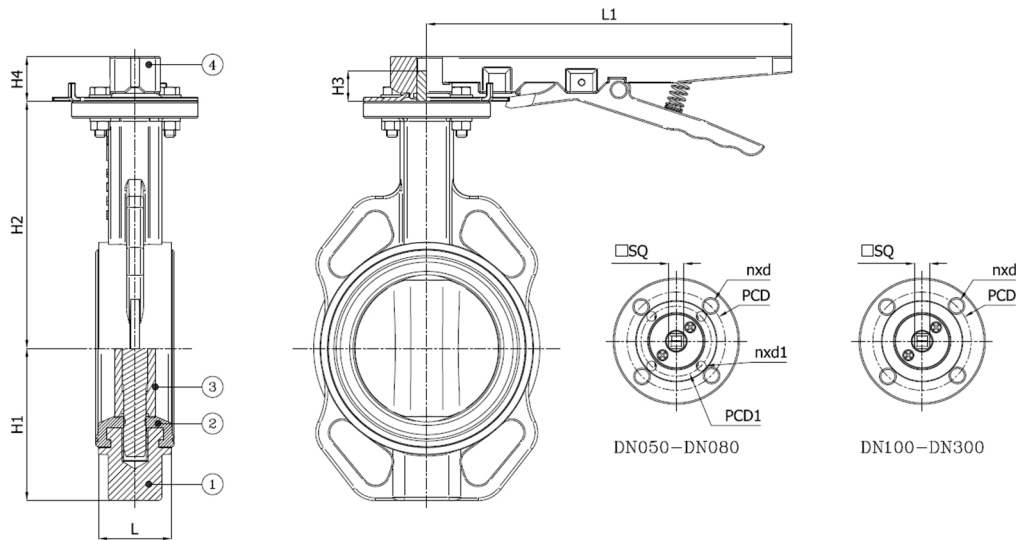

DN/Size	L	H1	H2	H3	H4	L1	SQ	ISO	PCD	n x d1	PCD1	ISO1	n x d	Press.Cl.	Weight(kg)
DN050 (2")	43	64	140,5	22	29	260	11	F05	50	4 x d10	70	F07	4 x d7	PN16	4.00
DN065 (2 1/2")	46	71,4	152,5	22	29	260	11	F05	50	4 x d10	70	F07	4 x d7	PN16	4.70
DN080 (3")	46	94	157,5	22	29	260	11	F05	50	4 x d10	70	F07	4 x d7	PN16	5.10
DN100 (4")	52	108,5	176	22	29	260	14	F07	70	4 x d10				PN16	6.60
DN125 (5")	56	119	191	22	29	260	14	F07	70	4 x d10				PN16	8.40
DN150 (6")	56	136	202,5	22	29	260	14	F07	70	4 x d10				PN16	9.90
DN200 (8")	60	165	243,5	34,5	45	350	17	F10	102	4 x d12				PN16	18.50
DN250 (10")	68	202	273	34,5	45	350	22	F10	102	4 x d12				PN16	25.00
DN300 (12")	78	235	311	34,5	45	350	27	F12	125	4 x d14				PN16	36.00

Item 1	Item 2	Item 3	Item 4
Body Material	Seat Material	Disc Material	Actuator Material
Cast iron : GG25 + Epoxy coating	FPM	Stainless steel : CF8M	Malleable iron

Belven N.V.

Blokhuisstraat 24 | 2800 Mechelen | Belgium

Tel. 015 29 40 70 | Fax. 015 20 14 13 | info@belven.com | www.belven.com

We keep the right to change the mentioned dimensions, weights, values and materials at any time without prior or direct notice.