

Technical Product Sheet

BV4-4766R-PN40 - Aluminium Gearbox

Ball valve, full bore, split body, flanged PN40, with Rotork gearbox

Face to Face Standard: EN 558-1 series 27



Item Number	Belven Ref.
045D07F5065	BV4-4466R-PN40-DN065 - GEARBOX
045D07F5080	BV4-4466R-PN40-DN080 - GEARBOX
045D07F5100	BV4-4466R-PN40-DN100 - GEARBOX
045D07F5150	BV4-4466R-PN40-DN150 - GEARBOX

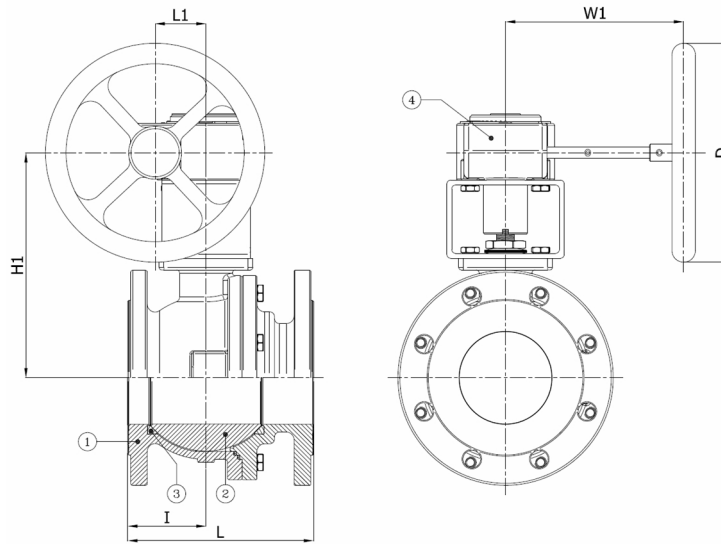

DN/Size	L	H1	I	L1	W1	D	Press.Cl.	Weight(kg)
DN065 (2 1/2")	170	181	61	46	166	125	PN40	21.60
DN080 (3")	180	217	75,5	52	194	224	PN40	25.80
DN100 (4")	190	230	80	52	194	224	PN40	32.90
DN150 (6")	350	315	157	65	236	256	PN40	89.60

Item 1	Item 2	Item 3	Item 4
Body Material	Ball Material	Seat Material	Actuator Material
Low-temperature steel : 1.1156 (LCB)	Stainless steel : A182-F304 / A351-CF8	RPTFE	Aluminium

Belven N.V.

Blokhuisstraat 24 | 2800 Mechelen | Belgium

Tel. 015 29 40 70 | Fax. 015 20 14 13 | info@belven.com | www.belven.com

We keep the right to change the mentioned dimensions, weights, values and materials at any time without prior or direct notice.