

# Technical Product Sheet

## BV4-4766T-A150 - Aluminium Gearbox

Ball valve, full bore, split body, flanged ANSI 150lbs, with Rotork gearbox  
Face to Face Standard: ANSI B16.10



Item Number	Belven Ref.
047A07F5015	BV4-4766T-A150-DN015 - GEARBOX
047A07F5020	BV4-4766T-A150-DN020 - GEARBOX
047A07F5025	BV4-4766T-A150-DN025 - GEARBOX
047A07F5040	BV4-4766T-A150-DN040 - GEARBOX
047A07F5050	BV4-4766T-A150-DN050 - GEARBOX
047A07F5080	BV4-4766T-A150-DN080 - GEARBOX
047A07F5100	BV4-4766T-A150-DN100 - GEARBOX
047A07F5150	BV4-4766T-A150-DN150 - GEARBOX
047A07F5200	BV4-4766T-A150-DN200 - GEARBOX

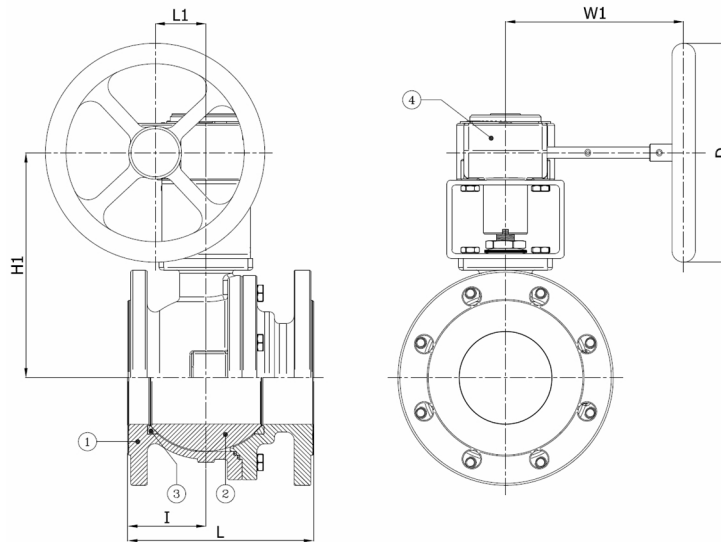

DN/Size	L	H1	I	L1	W1	D	Press.Cl.	Weight(kg)
DN015 (1/2")	108	110	46,5	45	119	100	A150	4.20
DN020 (3/4")	117	115	53	45	119	100	A150	4.70
DN025 (1")	127	132	59,5	45	119	100	A150	6.10
DN040 (1 1/2")	165	164	77	46	166	125	A150	9.50
DN050 (2")	178	169	86	46	166	125	A150	15.30
DN080 (3")	203	217	79,5	52	194	224	A150	25.80
DN100 (4")	229	230	110	52	194	224	A150	34.30
DN150 (6")	394	315	181	65	236	256	A150	86.50
DN200 (8")	457	360	212	80	376	400	A150	131.50

Item 1	Item 2	Item 3	Item 4
Body Material	Ball Material	Seat Material	Actuator Material
Low-temperature steel : A352 LCB	Stainless steel : A182-F304 / A351-CF8	PTFE	Aluminium

Belven N.V.

Blokhuisstraat 24 | 2800 Mechelen | Belgium  
Tel. 015 29 40 70 | Fax. 015 20 14 13 | [info@belven.com](mailto:info@belven.com) | [www.belven.com](http://www.belven.com)

We keep the right to change the mentioned dimensions, weights, values and materials at any time without prior or direct notice.