

BV38-2345E-PN10/PN16

Clapet anti-retour à battant, montage "sandwich" entre brides PN10/16

Norme d'écartement: Standard d'usine



N° d'article	Réf. Belven
383035E0050	BV38-2345E-PN16-DN050
383035E0065	BV38-2345E-PN16-DN065
383035E0080	BV38-2345E-PN16-DN080
383035E0100	BV38-2345E-PN16-DN100
383035E0125	BV38-2345E-PN16-DN125
383035E0150	BV38-2345E-PN16-DN150
383035E0200	BV38-2345E-PN16-DN200
383035E0250	BV38-2345E-PN16-DN250
383035E0300	BV38-2345E-PN16-DN300

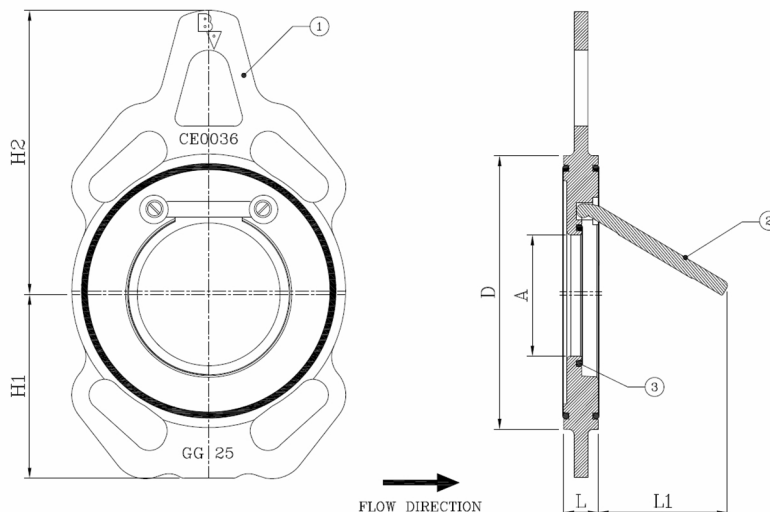

DN/Pouce	L	H1	D	A	L1	H2	Cl. press.	Poids(kg)
DN050 (2")	18	65	99	32	44	130	PN16	1,20
DN065 (2 1/2")	20	72	118	40	52	140	PN16	1,80
DN080 (3")	20	94	132	54	62	150	PN16	2,10
DN100 (4")	20	108	158	70	78	162	PN16	2,90
DN125 (5")	22	120	184	92	95	175	PN16	3,80
DN150 (6")	22	135	215	112	114	188	PN16	4,90
DN200 (8")	22	165	265	154	153	220	PN16	7,50
DN250 (10")	29	202	319	200	195	250	PN16	12,70
DN300 (12")	38	325	370	240	229	288	PN16	21,20

Item 1	Item 2	Item 3
Matériau Corps	Matériau Clapet	Matériau Siège
Fonte : GG25 + revêtement epoxy	Acier au carbone	EPDM