

BV38-4545E-PN10/PN16

Clapet anti-retour à battant, montage "sandwich" entre brides PN10/16

Norme d'écartement: Standard d'usine



N° d'article	Réf. Belven
383055N0032	BV38-4545E-PN16-DN032
383055N0040	BV38-4545E-PN16-DN040
383055N0050	BV38-4545E-PN16-DN050
383055N0065	BV38-4545E-PN16-DN065
383055N0080	BV38-4545E-PN16-DN080
383055N0100	BV38-4545E-PN16-DN100
383055N0125	BV38-4545E-PN16-DN125
383055N0150	BV38-4545E-PN16-DN150
383055N0200	BV38-4545E-PN16-DN200

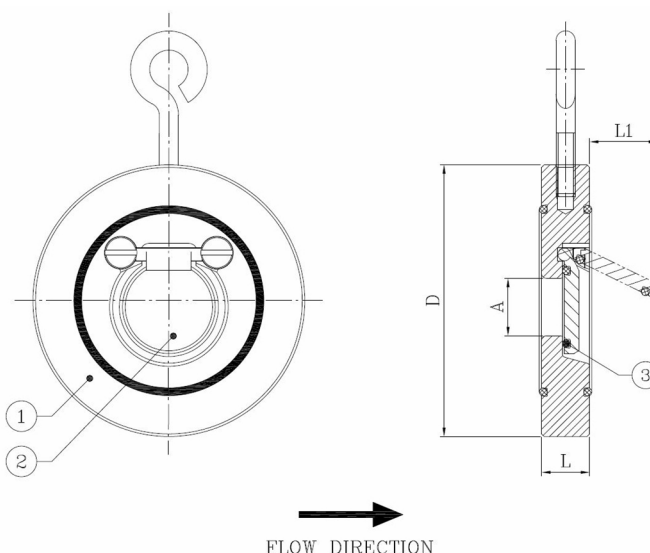

DN/Pouce	L	D	A	L1	Cl. press.	Poids(kg)
DN032 (1 1/4")	15	85	18	22	PN16	0,60
DN040 (1 1/2")	16	95	22	25	PN16	0,80
DN050 (2")	14	109	32	37	PN16	0,90
DN065 (2 1/2")	14	129	40	50	PN16	1,20
DN080 (3")	14	144	54	61	PN16	1,50
DN100 (4")	18	164	70	77	PN16	2,40
DN125 (5")	18	195	92	98	PN16	3,30
DN150 (6")	20	220	112	120	PN16	4,60
DN200 (8")	22	275	154	160	PN16	7,70

Item 1	Item 2	Item 3
Matériau Corps	Matériau Clapet	Matériau Siège
Acier au carbone : 1.0619 (WCB) zingué	Acier au carbone : 1.0619 (WCB) zingué	EPDM